



# Neutron sources

Sealed sources that emit neutrons by spontaneous fission are used in a range of activities, including geological prospecting, moisture gages for industrial/agronomic applications, activity analysis, nuclear research, commissioning of nuclear reactors, nucleonic instrumentation in the nuclear fuel cycle, oil industry research, nuclear logging tools for oil and mineral exploration, explosives and/or narcotics detection systems, and irradiation sources for research and for calibration of radiation detectors and health physics instrumentation.

## 1) Americium-241 / Beryllium

A homogeneous mixture of americium-241 oxide and beryllium metal is enclosed in a double capsule made from stainless steel welded using the TIG process.

### • Source reference system

*Radionuclide*  
**AM241SNA03 3,7GBQ**  
*Neutron source*

*Type of capsule (dimensions, single/double capsule)*  
**3,7GBQ**  
*Required activity (3,7 GBq)*

### • Available packaging

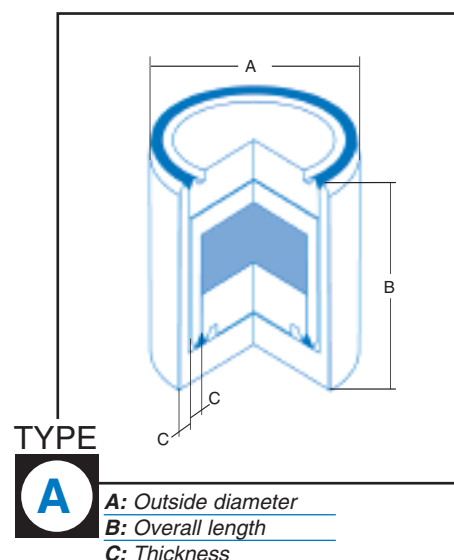

Basic reference	Maximum activity		Dimensions (mm)			Encapsulation	Classification ISO 2919
	GBq	Ci	A	B	C		
<b>SNA02</b>	1,5	0,04	8	10	0,8	double	C66545
<b>SNA03</b>	11,1	0,3	17	19	0,8	double	C66544
<b>SNA04</b>	1,5	0,04	8	15	0,8	double	C66544
<b>SNA05</b>	370	10	27	130	2,5	double	C66545
<b>SNA20</b>	185	5	19,1	48,6	1,4	double	C66546



## 2) Californium-252

LEA can supply other double-encapsulated neutron sources (californium-252-type) on request.

The contained activity is given as a nominal value  $\pm 15\%$

A calibration certificate with an uncertainty measurement at  $\pm 5\%$  is available inoptun.

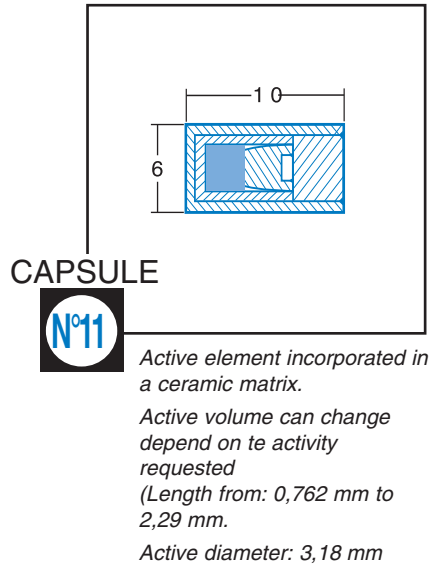
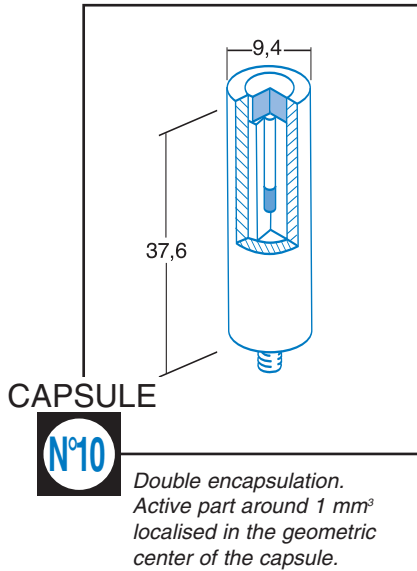

## • Source reference system

radionuclide      Type of capsule  
**CF252SNA10ACTIVITE**  
 Neutron source      Required activity

Product code	Maximum activity		Encapsulation
	MBq	mCi	
CF252SNA10	18,5	0,5	double
CF252SNA11	18,5	0,5	double

## • Other Cf<sup>252</sup> neutron sources with stronger activities are also available